



## TECHNICAL INFORMATION

# Rod Seals | Zurcon® Rimseal

### Description

When the field of application and system requirements make high demands on leakage control and operational reliability, a redundant sealing system is necessary to ensure reliable sealing of hydraulic cylinders at the piston rod. Sealing systems with elastomer-energized polymer seals are a proven answer to widely varying demands for standardized grooves, simple installation, resistance to media, high and low temperatures and pressures.

The system offers enormous flexibility in the choice and matching of materials. The piston rod sealing system for hydraulic cylinders subject to heavy loads should consist of three elements:

The Turcon® Stepseal® 2K or V used as primary seal. This seal element offers the back pumping property necessary for redundant rod seal

systems as well as good resistance to high and low temperatures and high media resistance.

The Zurcon® Rimseal was developed as the secondary seal in this system to ensure reliable sealing of thin oil films at low secondary pressures. A Zurcon® material (polyurethane Shore D 58) is used combined with a new seal profile. The contact pressure curve is automatically optimized under dynamic conditions. The final outer element of the redundant sealing system is a double-acting scraper seal (e.g. DA24, DA 22, Turcon® Excluder® 2). The optimum sealing system thus consists of three independent lip seals installed in line, whereby the hardness of the material decreases from the pressure side to the atmospheric side.

### Advantages

- High static and dynamic leak tightness
- Low friction for reduced power loss
- High wear resistance for long service life
- Small groove
- Easy installation
- Optimum system element
- ISO/DIN grooves optional
- Available a range of diameters from 10 to 250 mm



### Technical Data

Pressure	:	In tandem system	:	Up to 60 MPa
		As an individual element	:	25 MPa
Speed	:	5 m/s with short strokes (<1 m) in tandem system		
Temperature	:	-45 °C to +110 °C (depending on O-Ring material)		
Media	:	Hydraulic fluids, Mineral oil, Synthetic and natural esters, HEES. HETG up to +60°C, Flame retardant fluids HFA, HFC		
Clearance	:	The maximum permissible radial clearance $S_{max}$ is shown in the table on the next page as a function of the operating pressure and functional diameter.		



## TECHNICAL INFORMATION

# Rod Seals | Zurcon® Rimseal

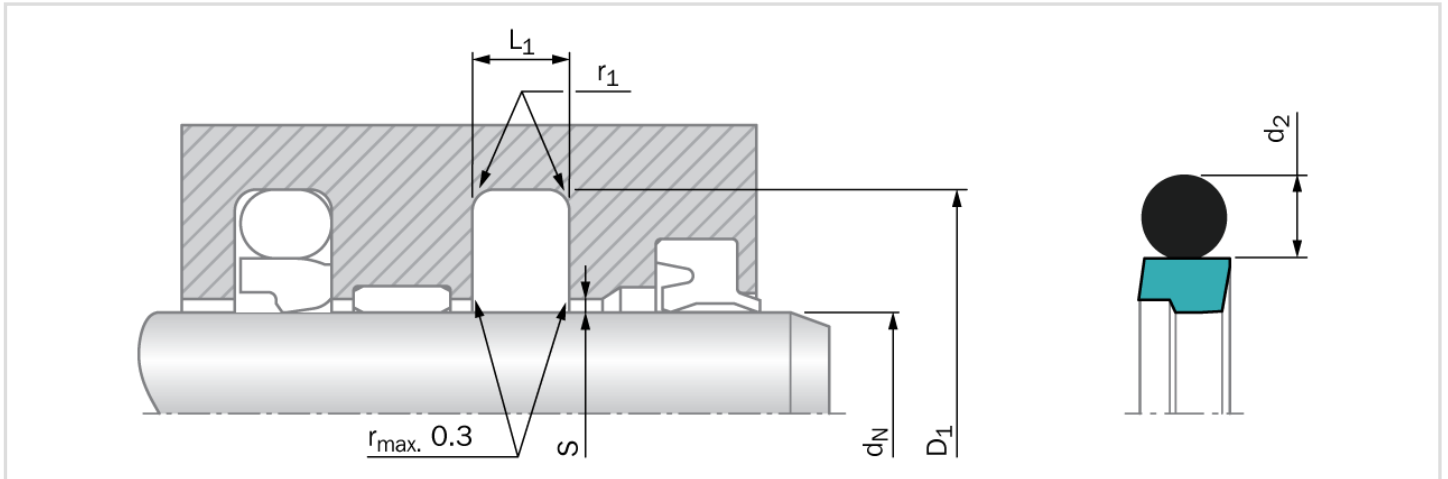

### Installation dimensions - Standard recommendations

Rod Diameter $d_N$ f8/h9			Groove Diameter	Groove Width	Radius	Radial Clearance $S_{max.}$		O-Ring Cross- Section
Series No. RR 13 Standard Application	Series No. RR 15 Light Application	Series No. RR 11 Heavy Duty Application	$D_1$ H9	$L_1 + 0.2$	$r_1$	10 MPa	20 MPa	$d_2$
8 - 18.9	19 - 37.9	-	$d_N + 7.3$	3.2	0.6	0.40	0.25	2.62
19 - 37.9	38 - 199.9	8 - 18.9	$d_N + 10.7$	4.2	1.0	0.40	0.25	3.53
38 - 199.9	200 - 255.9	19 - 37.9	$d_N + 15.1$	6.3	1.3	0.50	0.30	5.33
200 - 255.9	256 - 649.9	38 - 199.9	$d_N + 20.5$	8.1	1.8	0.60	0.35	7.00
256 - 649.9	650 - 999.9	200 - 255.9	$d_N + 24.0$	8.1	1.8	0.60	0.35	7.00
650 - 999.9	1000 - 2200	256 - 649.9	$d_N + 27.3$	9.5	2.5	0.70	0.50	8.40
1000 - 2200	-	650 - 999.9	$d_N + 38.0$	13.8	3.0	1.00	0.70	12.00*

\* All O-Rings with 12 mm cross section are delivered as special profile ring. Installation in closed grooves from diameters > 18mm. Also for installation according to ISO 7425-2.

### Important Note

Installation suggestions, material recommendations, parameters and further data provided are always subject to the particular field of use and the application in which the seal is intended to be used, in particular the interaction of the seal with other components of the application. Therefore they neither constitute an agreement on the legal and factual nature nor a guarantee of quality. Technical changes and errors remain reserved.