



TECHNICAL INFORMATION

Rotary Seals | Radial Oil Seal Type TRA

Description

Rotary shaft lip seals are components designed in a ring form, fitted between machine parts in relative rotation, with the function of separating oil or grease from the inside and dirt, dust, water etc. from the outside. The radial shaft seal consists of two main parts:

A cylindrical outer covering of sheet steel (case) or an elastomer that has the requisite interference fit to seal statically against the housing bore.

A sealing lip made of an elastomeric material that seals dynamically and statically against the shaft. The lip has a sealing edge that is formed by molding, cutting, or grinding. It is normally

pressed against the counter face surface of the shaft, with a defined radial load, by a garter spring. The edge of the sealing lip and the shaft counter face surface form the most important functional area of a radial shaft seal.

Radial Oil Seal type TRA are seals with completely rubber covered outer diameter and a single sealing lip. The TRA type is not recommended for use in heavily polluted environments.

Radial Oil Seal type TRA is typically used in transmission systems (e.g. gearboxes), pumps, electrical motors, and machine tools.

Advantages

- Good static sealing
- Compensation of different thermal expansion
- Reduced risk of fretting and/or corrosion
- Higher bore surface roughness is allowed
- Installation in split housings
- Modern lip design provides low radial forces



Technical Data

Pressure	: Up to 0.05 MPa
Temperature	: -40 °C to +200 °C (depending on material)
Speed	: Up to 30 m/s (depending on material)
Media	: Mineral and synthetic lubricants (CLP, HLP, APGL etc.)



TECHNICAL INFORMATION

Rotary Seals | Radial Oil Seal Type TRA

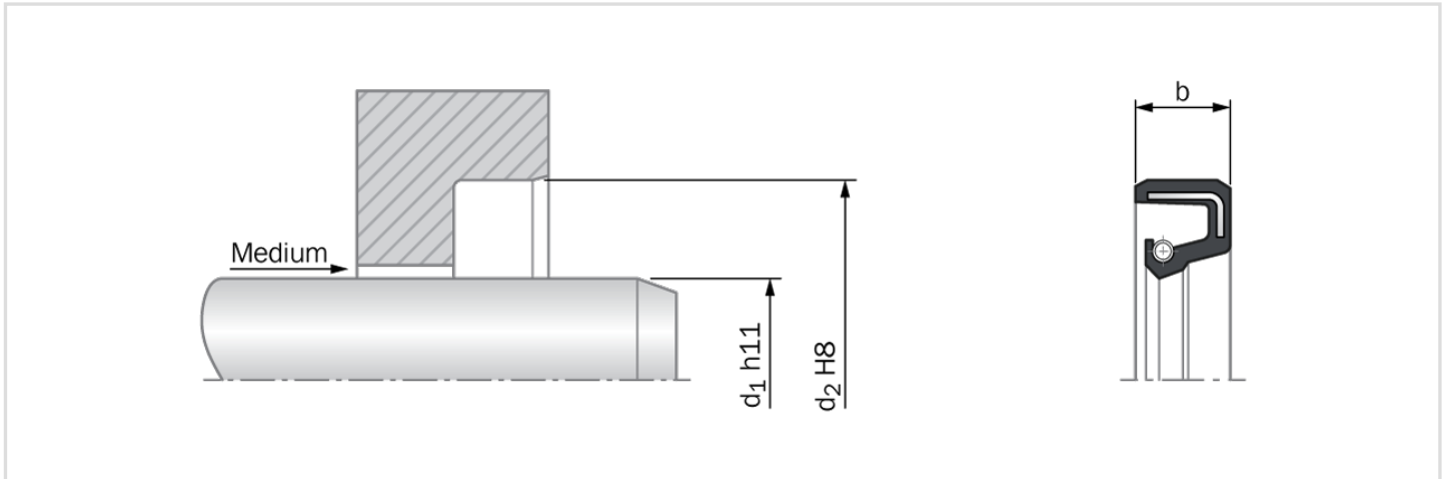

Important Note

Installation suggestions, material recommendations, parameters and further data provided are always subject to the particular field of use and the application in which the seal is intended to be used, in particular the interaction of the seal with other components of the application. Therefore they neither constitute an agreement on the legal and factual nature nor a guarantee of quality. Technical changes and errors remain reserved.