

TECHNICAL INFORMATION

Slydring® Wear Rings | Orkot® Slydring® for Rod

Description

Orkot® Slydring® of fabric reinforced composite materials is used in hydraulic cylinders exposed to high loads that can occur e.g. in mobile hydraulics and presses. The high compressive strength, good sliding behaviour and the exceptional wear resistant properties ensure a long service life.

Slydring® of Orkot® fabric composite materials is produced as standard preformed to the intended diameter and ready-to-fit. It is manufactured with an angle cut and already has the necessary gap "Z₁".

Orkot® C380 is a turquoise colored composite material made of a thermosetting polymer, reinforced by a fine plastic mesh and lubricant additives impregnated throughout the material. It is most versatile; suitable for all commonly used

hydraulic fluids such as mineral or synthetic oils, as well as water based fluids. It is an excellent electrical insulator and features enhanced sliding properties in various media.

Orkot® Slydring® is widely used as a bearing element for heavy duty hydraulic equipment:

- Hydraulic actuators
- Mobile hydraulics
- Excavators
- Construction equipment
- Forestry machinery
- Mining
- Steel mills
- Presses
- Water locks
- Marine engineering

Advantages

- Dimensionally stable and vibration absorbing
- Even distribution of high radial forces
- Good sliding and dry running properties
- High wear resistance
- Good wiping effect
- Long service life

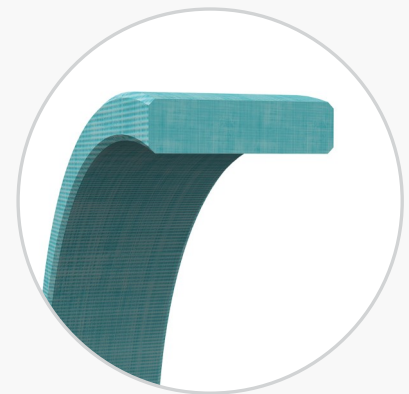

Technical Data

Velocity	:	Up to 1 m/s, with reciprocating movements
Temperature	:	-60 °C to +120 °C
Pressure under dynamic conditions	:	max. 100 N/mm ² at 25 °C max. 50 N/mm ² > 60 °C

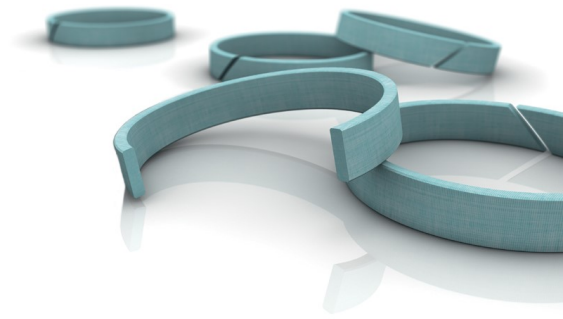

TECHNICAL INFORMATION

Slydring® Wear Rings | Orkot® Slydring® for Rod

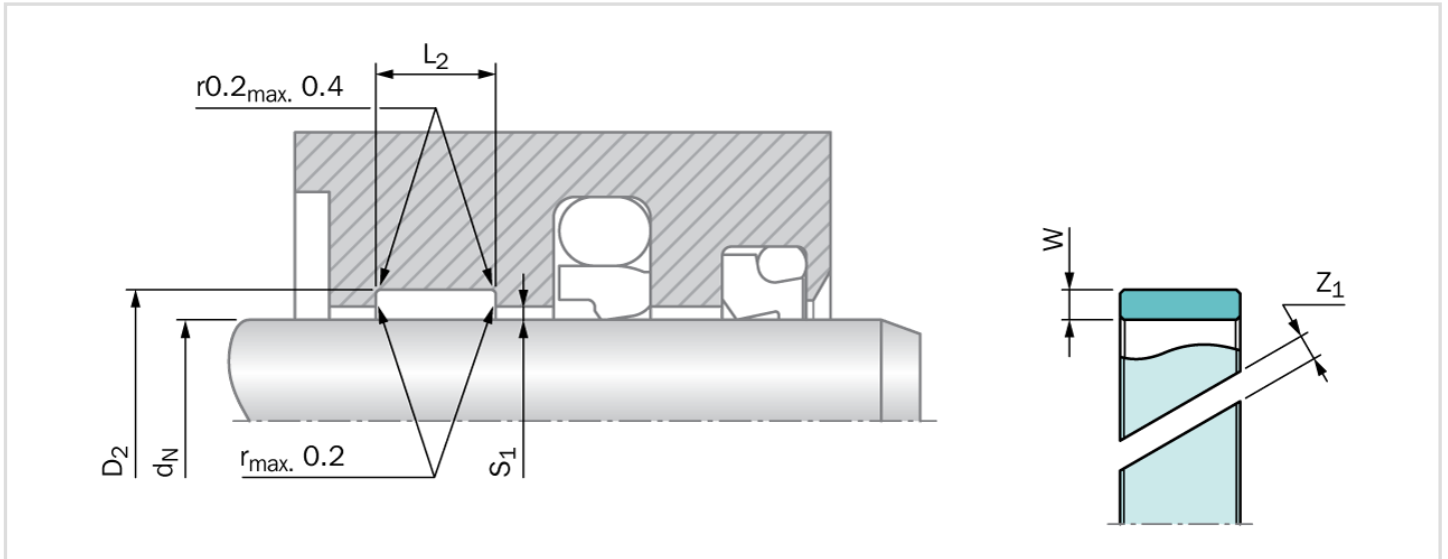

Installation dimensions - Standard recommendations

Serial No.	Rod Diameter* d_N f8/h9	Groove Diameter D_2 H8	Groove Width $L_2 +0.2$	Ring Thickness W	Ring Gap** Z_1
GR43	8 - 50.0	$d_N + 3.10$	4.00	1.55	1 - 3
GR65	16 - 120.0	$d_N + 5.00$	5.60	2.50	2 - 6
GR69	25 - 250.0	$d_N + 5.00$	9.70	2.50	2 - 9
GR73	75 - 500.0	$d_N + 5.00$	15.00	2.50	4 - 17
GR75	120 - 999.9	$d_N + 5.00$	25.00	2.50	5 - 33
GR75X	1000 - 1500.0	$d_N + 5.00$	25.00	2.50	33 - 49
GR98	280 - 999.9	$d_N + 8.00$	25.00	4.00	10 - 33
GR98X	1000 - 1500.0	$d_N + 8.00$	25.00	4.00	33 - 48

* Recommended diameter ranges

** See Figure below

Recommended Radii for Groove Diameter

D_N	r max.
8 - 250	0.2
> 250	0.4

Surface Roughness

Parameter	Mating Surface μm	Groove Surface μm
R_{max}	1.00 - 4.00	< 16.0
R_z DIN	0.63 - 2.50	< 10.0
R_a	0.10 - 0.40	< 2.5



TECHNICAL INFORMATION

Slydring® Wear Rings | Orkot® Slydring® for Rod



Important Note

Installation suggestions, material recommendations, parameters and further data provided are always subject to the particular field of use and the application in which the seal is intended to be used, in particular the interaction of the seal with other components of the application. Therefore they neither constitute an agreement on the legal and factual nature nor a guarantee of quality. Technical changes and errors remain reserved.