



## TECHNICAL INFORMATION

# Slydring® Wear Rings | Turcite® Slydring® for Rod

### Description

The Turcite® Slydring® is used as piston and rod guides due to their outstanding friction behavior, stick-slip free running and good resistance to high temperatures and chemicals.

The Slydring® has a geometrically rectangular cross-section and are chamfered at the edges for easy installation into the grooves.

Slydrings® up to and including 4 mm radial thickness in Turcite® materials are as standard supplied with “teardrop” structure on the sliding

surfaces. This structure comprises small lubricant pockets on the surface which improve the initial lubrication and promote the formation of a lubricant film. They also help to protect the seal system through their ability to embed any foreign particles. In order to be able to use the strip material for both piston and piston rod guides, the rings have this same teardrop structure on both sides.

### Advantages

- No stick-slip effect when starting for smooth operation even at very low speeds
- Minimum static and dynamic friction coefficient for low operating temperature and energy loss
- Outstanding lubrication conditions further improved by the Teardrop structure
- High wear resistance ensures long service life
- Installation grooves according to ISO 10766
- Suitable for most hydraulic fluids in relation with the majority of modern hardware materials and surface finish depending on material selected.
- Suitable for new environmentally safe hydraulic fluids
- The embedding of foreign particles is enhanced
- Good damping effect, absorbs vibrations



### Technical Data

Speed	: Up to 15 m/s
Temperature	: -60 °C to +150 °C
Media	: Mineral Oil based Hydraulic fluids, low flammability hydraulic fluids, environmentally safe hydraulic fluids (biological degradable oils) and others. Depending on the Turcite® material compatibility.
Clearance	: The maximum permissible radial clearance $S_{max}$ is shown in the table on the next page as a function of the operating pressure and functional diameter.
Radial Slydring® Side Load Pressure	: Max. 15 N/mm <sup>2</sup> at 25 °C Max. 12 N/mm <sup>2</sup> at 80 °C Max. 8 N/mm <sup>2</sup> at 120 °C

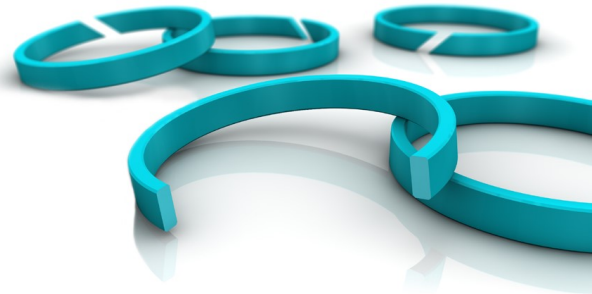

## TECHNICAL INFORMATION

# Slydring® Wear Rings | Turcite® Slydring® for Rod

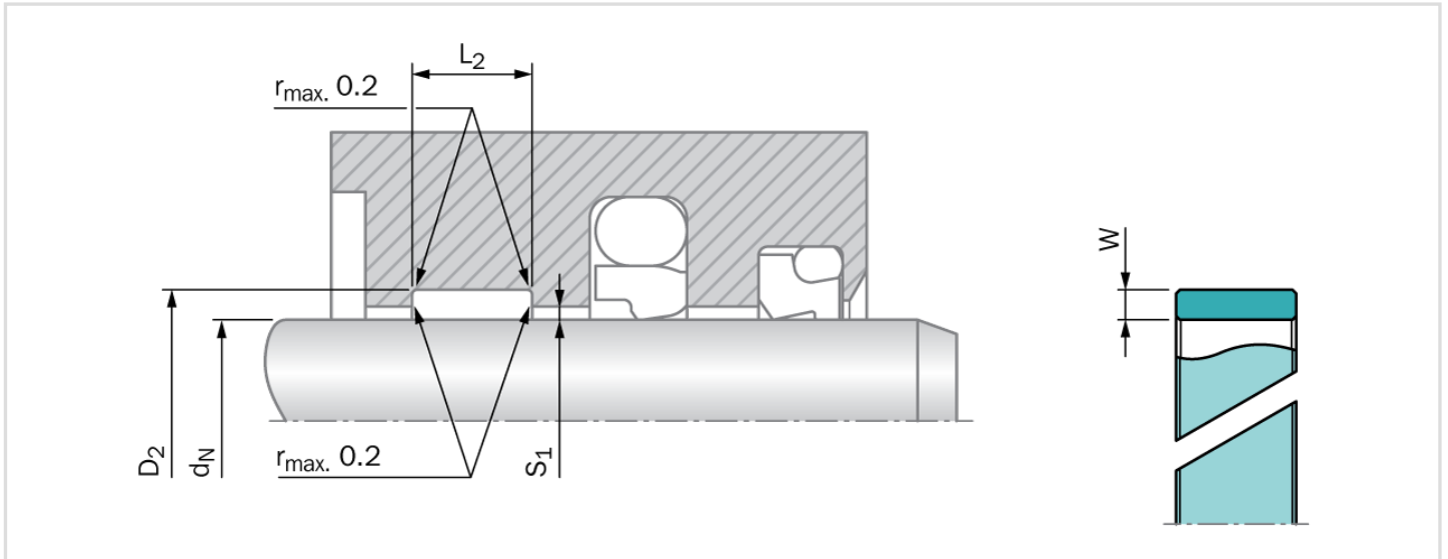

### Radial Clearance $S_1$ \*

Rod Diameter $d_N$	$S_{1 \text{ min.}}$	$S_{1 \text{ max.}}$
8 - 20	0.20	0.30
20 - 100	0.25	0.40
101 - 250	0.30	0.60
251 - 500	0.40	0.80
501 - 1000	0.50	1.10
> 1001	0.60	1.20

\* Specifications valid only in the area of the Slydring®, but not for the seal area. If the radial clearance  $S$  for the chosen seals is smaller than  $S_{1 \text{ min.}}$  there is risk for metal to metal contact.

### Important Note

Installation suggestions, material recommendations, parameters and further data provided are always subject to the particular field of use and the application in which the seal is intended to be used, in particular the interaction of the seal with other components of the application. Therefore they neither constitute an agreement on the legal and factual nature nor a guarantee of quality. Technical changes and errors remain reserved.